

lambert&fils

ISLE Collection
Brochure

May 2023



ISLE is an ode to quiet strength

Created by New York based Canadian
designer Zoë Mowat
in collaboration with Lambert & Fils



The Collection

A play on illusion and perception that allows lightness to anchor and foundations to rise. Composed of a delicate glass tube resting on solid-stone and aluminum pedestals and suspended in mid-air like a surreal bridge, ISLE is minimal, but never simplistic. The result is striking: blocks of mass both distinct and inextricably linked, like a bridge between two islands.

In keeping with the functional creativity of the studio, ISLE may hold a dreamlike quality, but it isn't merely decorative. Its system is simple yet integrated. Even the suspension wires are a part of the form and design. The lamp remains polymorphous; it is as much a practical object as an object of the imagination.

Isle 12 / Crédit image: Darius Laprise

Created to light a room and reveal the life within it, ISLE was designed to function in spaces large or small. The frosted glass tube diffuses the light evenly on its length and within the space it lives in.

While the single models are a great fit for residential spaces, the clusters are conceived for spacious areas. Composed of multiple modules, these sculptural pieces fill space horizontally in a linear structure or liven an area with volume in a vertical gesture.



Isle 03 B
Crédit image: Darius Laprise

The Models

Single models

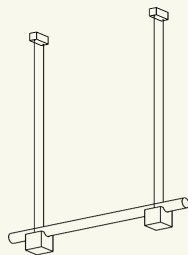

ISLE 01 A

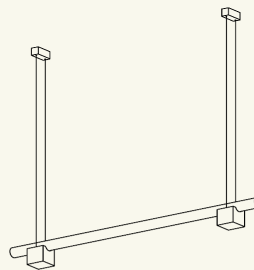

ISLE 02 A

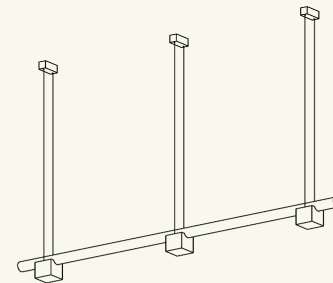

ISLE 03 A

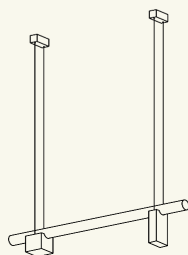
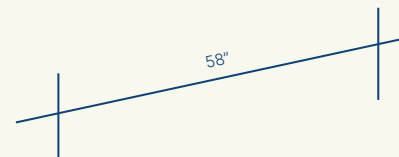
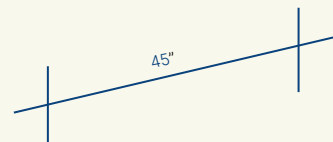
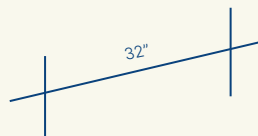

ISLE 01 B

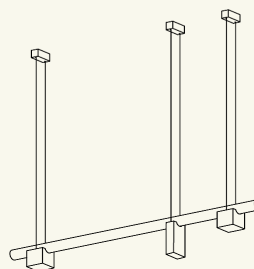

ISLE 02 B

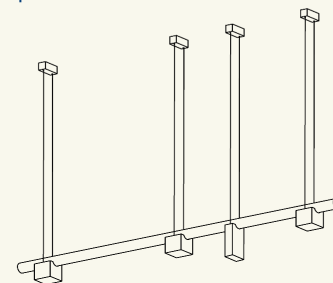

ISLE 03 B

Clusters

ISLE 10
(ISL02A + ISL03A)

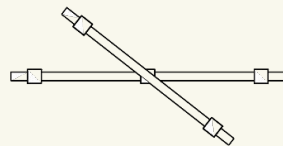
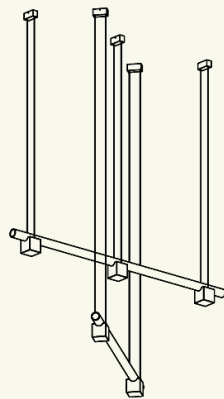

ISLE 11
(ISL02A+ ISL02B)

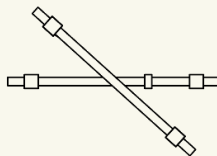
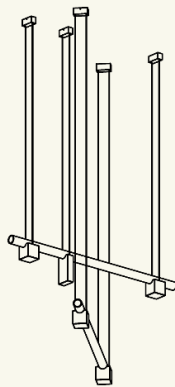

ISLE 12
(ISL01A + ISL02A+ ISL02B)

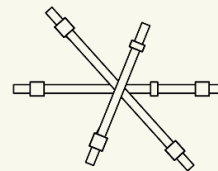
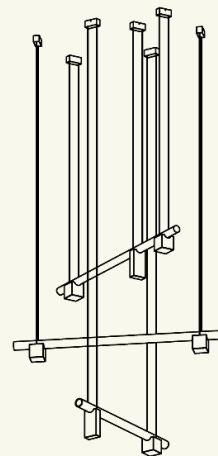

ISLE 13
(ISL01A + ISL02A+ ISL03A)

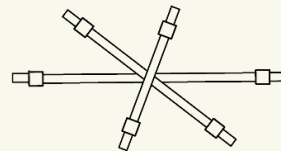
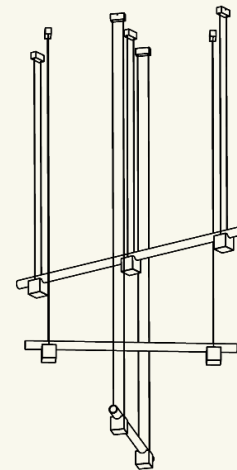

Clusters

ISLE 14
(ISL01B + ISL02B+ ISL03B)

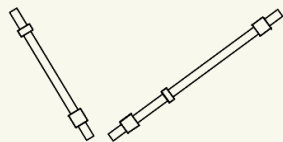
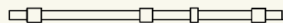
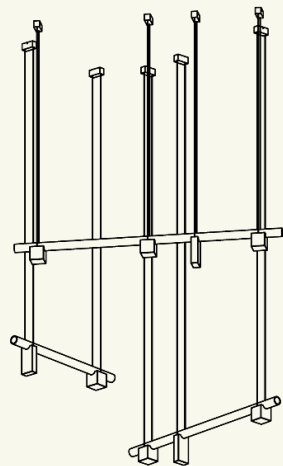

ISLE 15
(ISL01B + ISL03B)

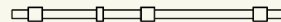
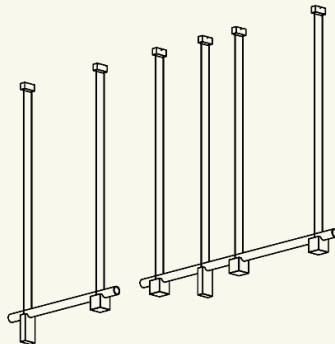

ISLE 16
(ISL01A + ISL02A+ ISL03A)

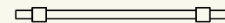
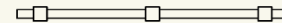
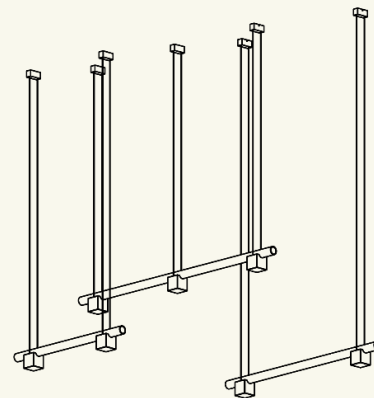

Design Process

Design Process

The design process between Zoë and the Lambert & Fils team was enriching and natural, a patient and meaningful journey. A winding map and indirect exploration led Zoë to the archetypal tube, then to the stone bases.

"We chose to work with Zoë for the strength of her work throughout the years but also because for me she's a pioneer of the new guard of Canadian designers. She has measured herself against the best international designers which I admire", —Samuel Lambert.

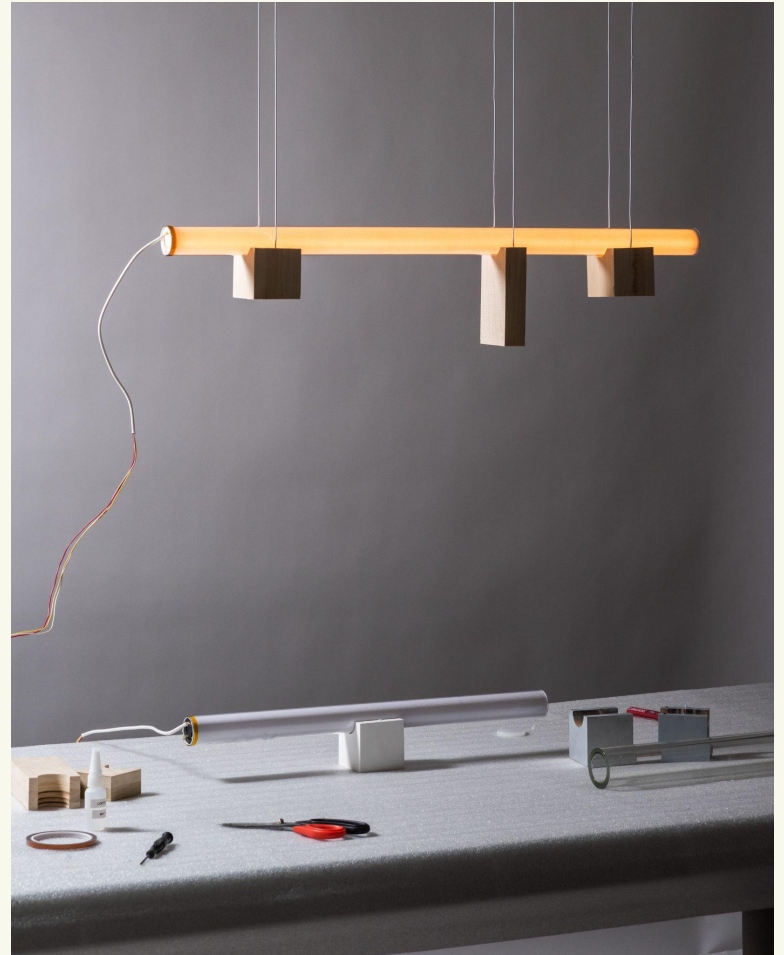





Samuel Lambert & Zoe Mowat Image credits: Arseni Khamzin

Zoë's practice focuses on the relationship between contrasting materials and textures, and the new forms which can emerge from those relationships. In developing ISLE, light itself became a material, a shape to explore: how to perceive it, how to integrate it, how to transcend it. *"We wanted to work in Zoë's language, without preconceived ideas"*, says Samuel Lambert.

Established in New York City, Zoë has developed the collection with the design team at Lambert & Fils through a remote collaboration between Montreal and Manhattan - two islands both strikingly different and complementary, reflecting the collection they have inspired.

zoemowat.com

“For me, ISLE is a play on contrasts — of matter and light, of mass and lightness. The versatile system honors and suspends solid volumes of material, exposing the materiality of light itself.”

-Zoë Mowat

Materiality

ISLE Collection has many layers of material coexisting within its design. The double layered elongated frosted glass tube enlightens and enhances the texture of the stones it rests on. Currently proposed in an array of deep strong marble square blocks and slabs, contrasting with the vivid polished aluminium of its end cap and block, the full ensemble creates a dynamic and versatile sculptural piece.

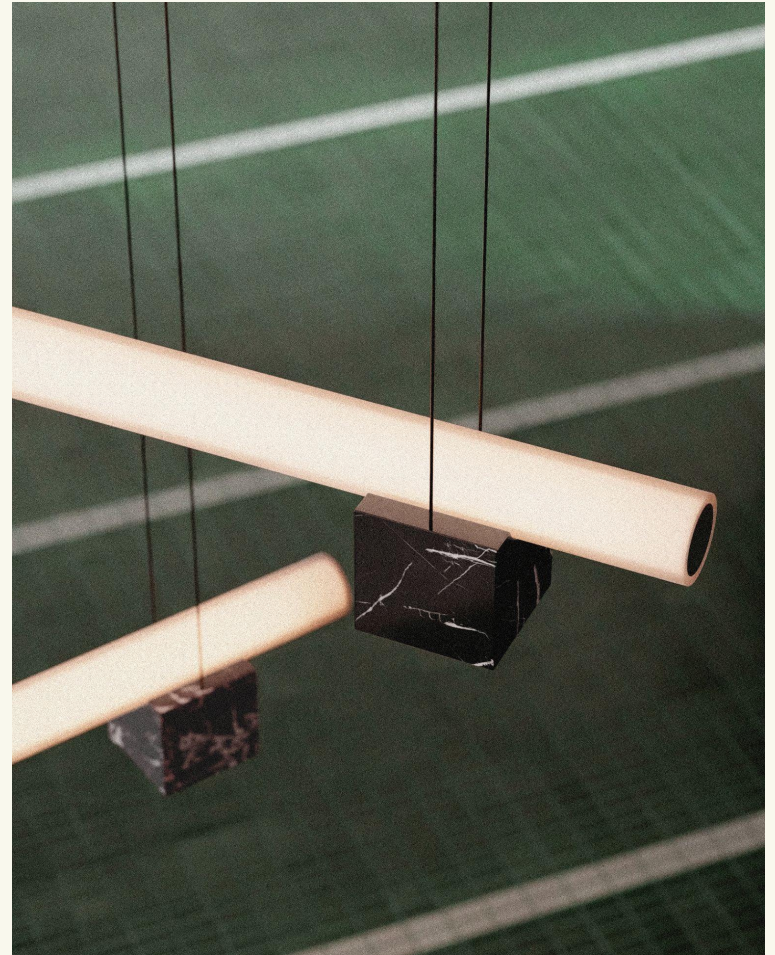



Nero Marquina

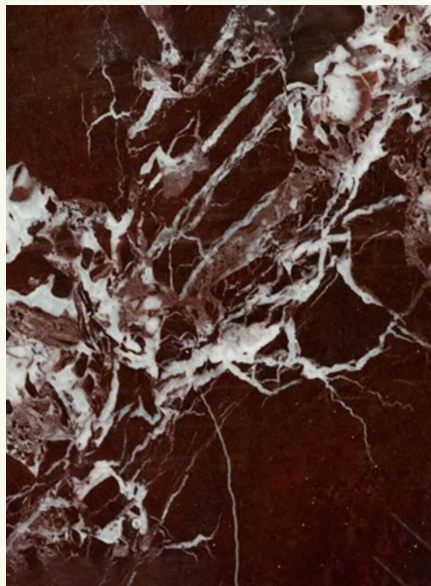

Rosso Levanto

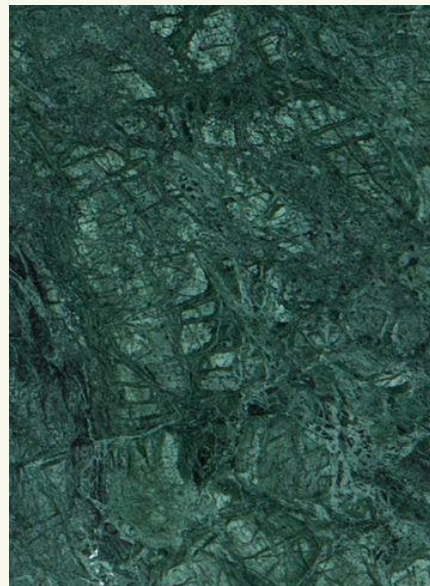

Guatemala Verde



Polished aluminium

more finishes to come in fall 2023

Canopies



Mechanical block

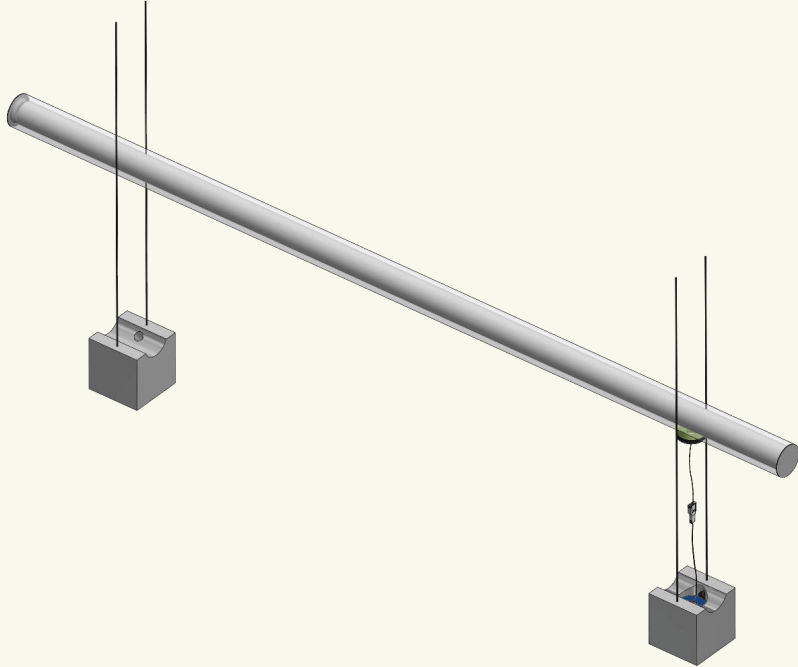

The tube is mainly laid on top of the slabs and blocks without any anchors, although each model is composed of at least one mechanical block that connects its LED panel in the glass tube to the to the electrical wires hidden in a block.

Technology

We develop and fabricate custom LED boards in order to replicate the intimacy and ambience of incandescent lighting. These quality measurements include:

- Advanced high quality LED
- A CRI of 90+, ensuring a colour rendering comparable to natural sunlight

Correlated Colour Temperature (CCT)

Our standard colour chart consists of the below:

- Warm Light 2700K
- Neutral light 3000K
- Dim-to-warm 2700K to 2200K
- Dim-to-warm 3000K to 2200K

All ISLE lights come equipped with a specific CCT selection available in 100K increments, from 2200K to 4000K inclusively.

Control

- 0-10V dimming (120V only)
- Phase dimming
- Dali (220-240V only)